



HATTERAS 80



FERRETTI NAVETTA 26



SUNSEEKER 80

# ABT·TRAC®

## 250 DIGITAL STABILIZERS

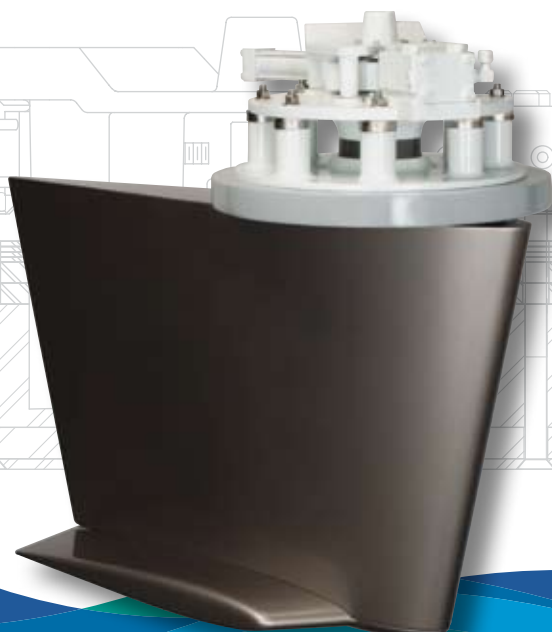

The user panel is a touch-screen LCD with large text and graphic keys. All important information is displayed on the Home screen. Low profile and small size (4" x 4.75") allow for easy mounting.

TRAC Digital Stabilizers dramatically improve ride comfort in any sea-state or wave angle. TRAC's 3-term control detects vessel motion and instantly adjusts fin position to counteract roll.

The TRAC exclusive touch-screen LCD user panel is simple and intuitive to operate. With one-touch activation, TRAC automatically adjusts for changes in sea-state, wave angle, and vessel speed.

TRAC's exclusive Fin and Winglet are computer optimized to generate more anti-roll force and less drag than conventional fins.

TRAC actuators feature a unique fail-safe capability that mechanically locks the fins when required. No more lifting floorboards or trips to the bilge to "pin the fins".

TRAC Stabilizers are built for heavy-duty service. Load bearing components are intentionally oversized. Double sealed shaft housings require no maintenance between haulouts. Our unique inboard hull flange mounting system speeds installation and eliminates costly, dry rot prone, wooden blocks.

TRAC systems are extensively documented and delivered ready-to-install. Key assemblies are factory tested, and cabling is custom fabricated for every vessel. Expert support is always available from factory technicians and through our global service network.

TRAC Digital Stabilizers are installed as standard equipment by more of the world's top yacht builders than any other brand. For exceptional performance, highest quality, and unmatched support, choose TRAC.

Taking Care Of You Every Step Of The Way.

# ABT·TRAC®

517-A Martin Avenue, Rohnert Park, CA 94928 USA  
TEL 707•586•3155 800•535•5377 FAX 707•586•3159  
www.thrusters.com

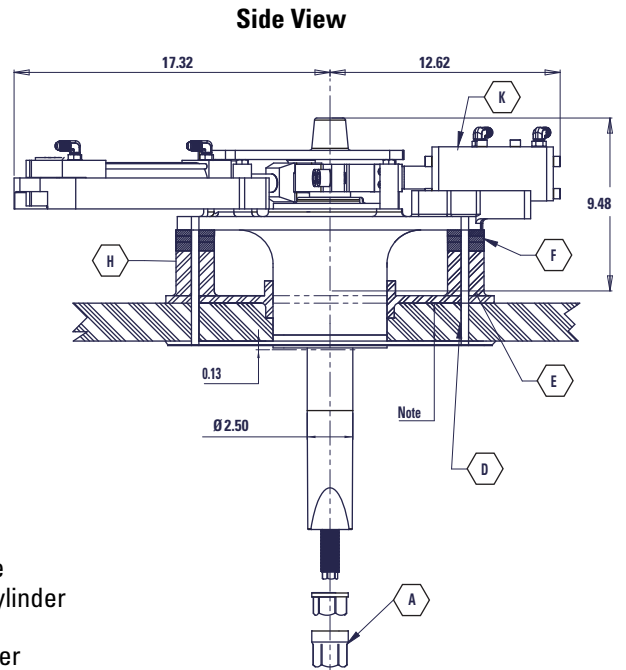
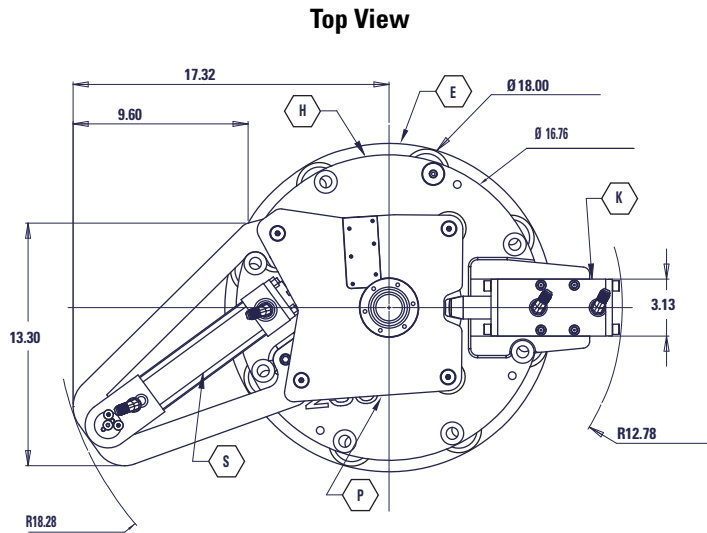

- A. Fin Nut
- D. Augmented hull thickness (Note)
- E. Inboard Hull Flange
- F. Hull Flange Spacer
- H. Actuator Flange
- K. Yoke Locking Cylinder
- P. Top Plate
- S. Actuator Cylinder

**Note:**

It is the responsibility of the installer to determine what reinforcement measures should be taken to properly strengthen the hull for withstanding forces that may be encountered if the fin or the fin shaft strikes an immovable object while the vessel is underway. Recommendations made by Arcturus Marine are to be used as starting guidelines only.

FIN SIZE	A	B	C	D	E	F
	Inch (cm)	Inch (cm)	Inch (cm)	Inch (cm)	Inch (cm)	Inch (cm)
4.5	35.5 (90.2)	8.5 (21.6)	20.8 (52.8)	26.9 (68.3)	1.1 (2.9)	12.1 (30.7)
6.0	41.0 (104.1)	9.8 (24.9)	23.9 (60.7)	31.0 (78.7)	1.3 (3.3)	14.0 (35.6)
6.0x	53.6 (136.1)	11.7 (29.7)	23.9 (60.7)	43.8 (111.3)	1.9 (4.8)	19.8 (50.3)
7.5	45.8 (116.3)	11.0 (27.9)	26.7 (67.8)	34.7 (88.1)	1.5 (3.7)	15.7 (39.9)
7.5x	61.1 (155.2)	13.4 (34.0)	26.7 (67.8)	50.0 (127.0)	2.2 (5.6)	22.6 (57.4)
9.0	50.2 (127.5)	12.0 (30.5)	29.3 (74.4)	38.0 (96.5)	1.6 (4.1)	17.2 (43.7)

Fins designated with an "X" suffix are extended chord fins for use in Stabilization At Rest (STAR<sup>™</sup>) systems.

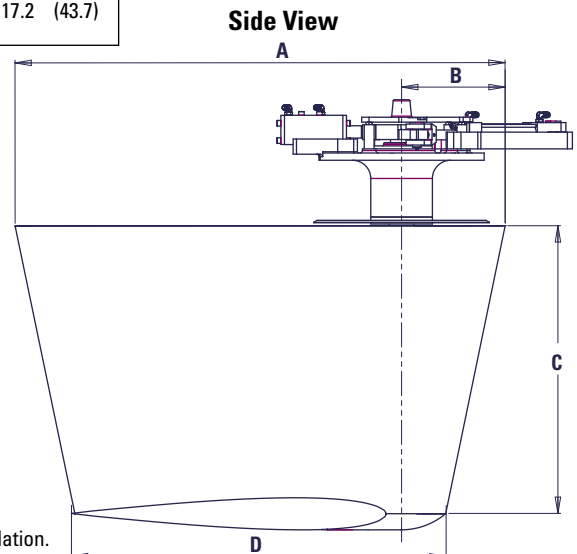
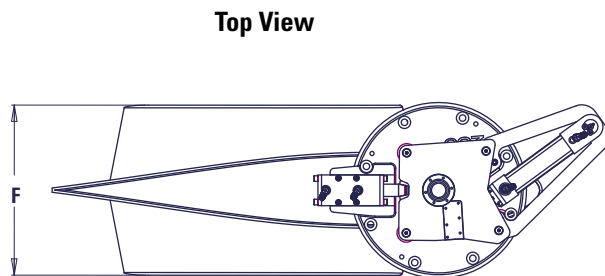

Dimensions shown for reference only and are subject to change. Do not use for installation.